

SERPAC M-6

Electronics Enclosures

NOTES:
 1. WHEN MACHINE OR I PLATES MODIFICATIONS ARE REQUIRED, USE THE CENTER OF THE ENCLOSURE TO DIMENSION.

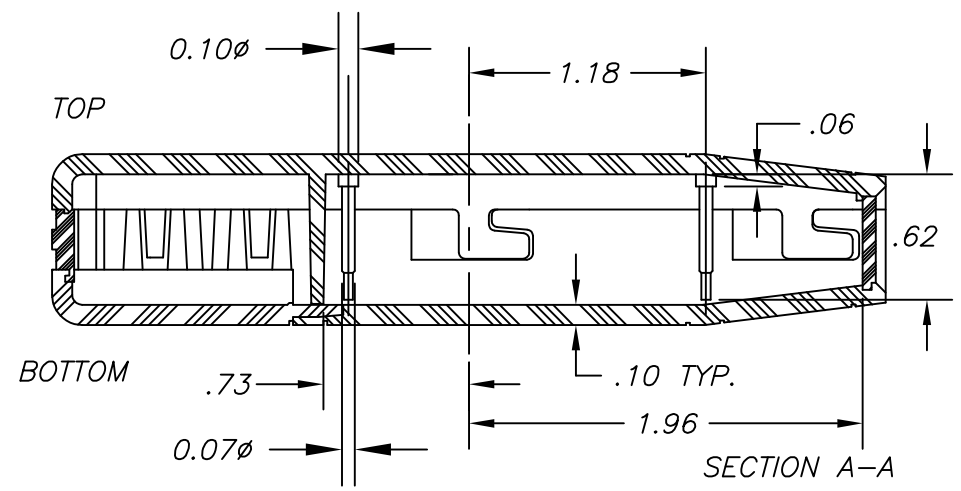
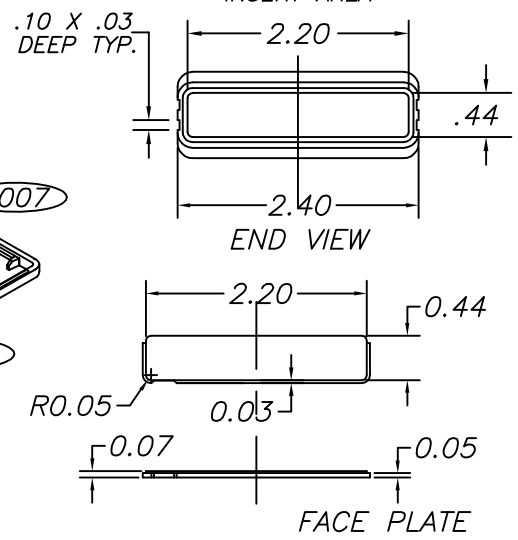
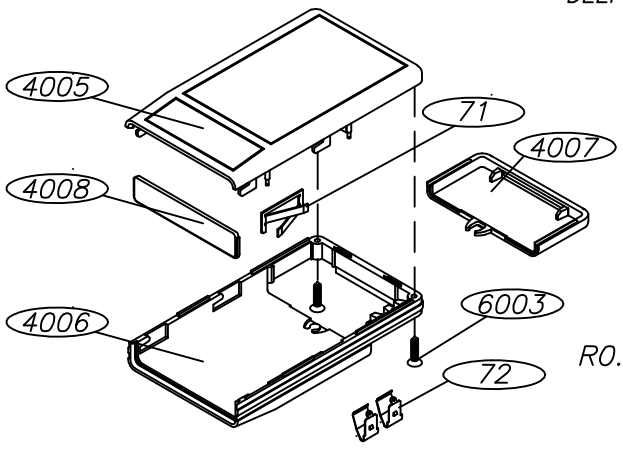
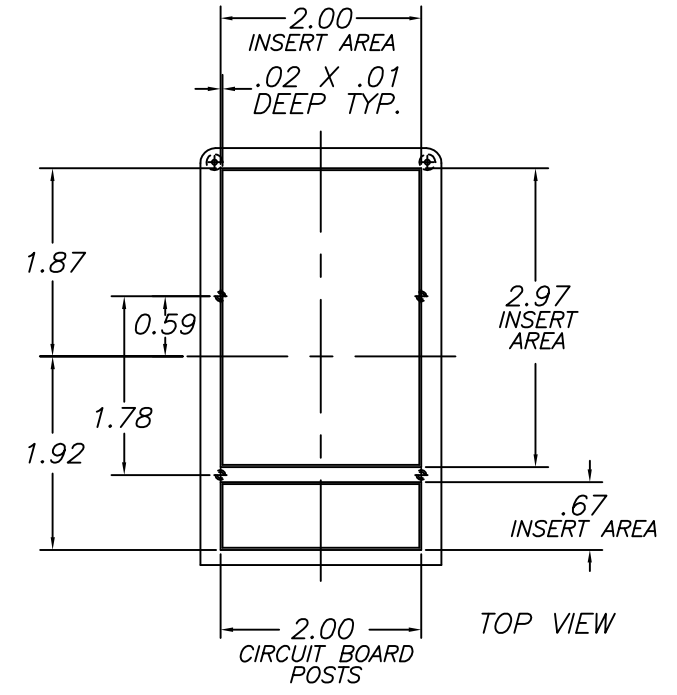
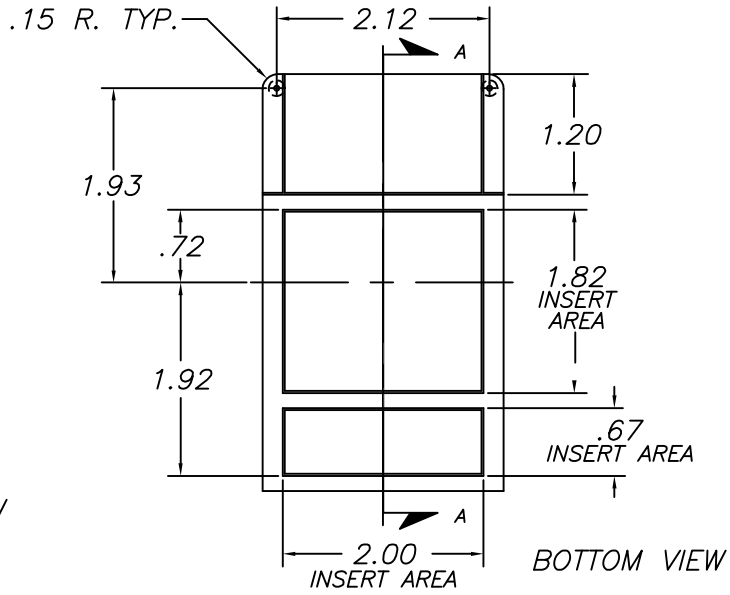
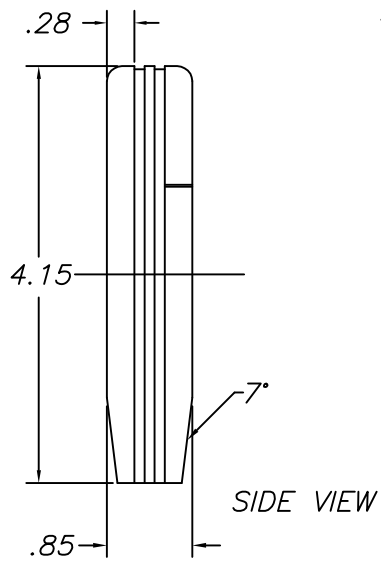

11-13-08. ALL DIMENSIONS ± .010

PART NO.	DESCRIPTION	ACCESSORIES	
		PART NO.	DESCRIPTION
4005	PLASTIC TOP	4008CL	CLEAR FACE PLATE
4008	PLASTIC FACE PLATE	4008IR	INFARED FACE PLATE
4006	PLASTIC BOTTOM	4008R	RED FACE PLATE
71	BATTERY CONTACT	1030	PLASTIC POCKET CLIP
4007	PLASTIC BATTERY COVER		
6003	SCREWS (2)		
72	BATTERY CONTACT		